



**FRIENDS** of the  
**RIVERFRONT**

# About Us:

- For over a decade, Friends of the Riverfront has been on the ground and in the water, working to protect and restore our region's priceless rivers and riverfronts. We are a pioneering organization that has been involved in creating nearly all of the trails you see as you bike, hike, rollerblade or paddle along our beautiful shores. Through intense collaboration with community partners, government officials, and diverse volunteer base, our rivers and riverfronts have been transformed from industrial wastelands to international examples of environmental renewal.

# Mission Statement:

- Increased awareness and engagement with the Pittsburgh region's rivers and riverfronts through activities, stewardship and expansion of water and land trails.

Land Trail Development

Water Trail Development

Stewardship

# Three Rivers Heritage Trail

- The Three Rivers Heritage Trail is a wonderful pedestrian trail and greenway system around the Pittsburgh region. Running for 21 miles along both sides of the Allegheny, Monongahela and Ohio Rivers, it is an almost complete public route for cyclists, walkers, runners, and in some places rollerbladers.



# Project Location – Route 28 Trail

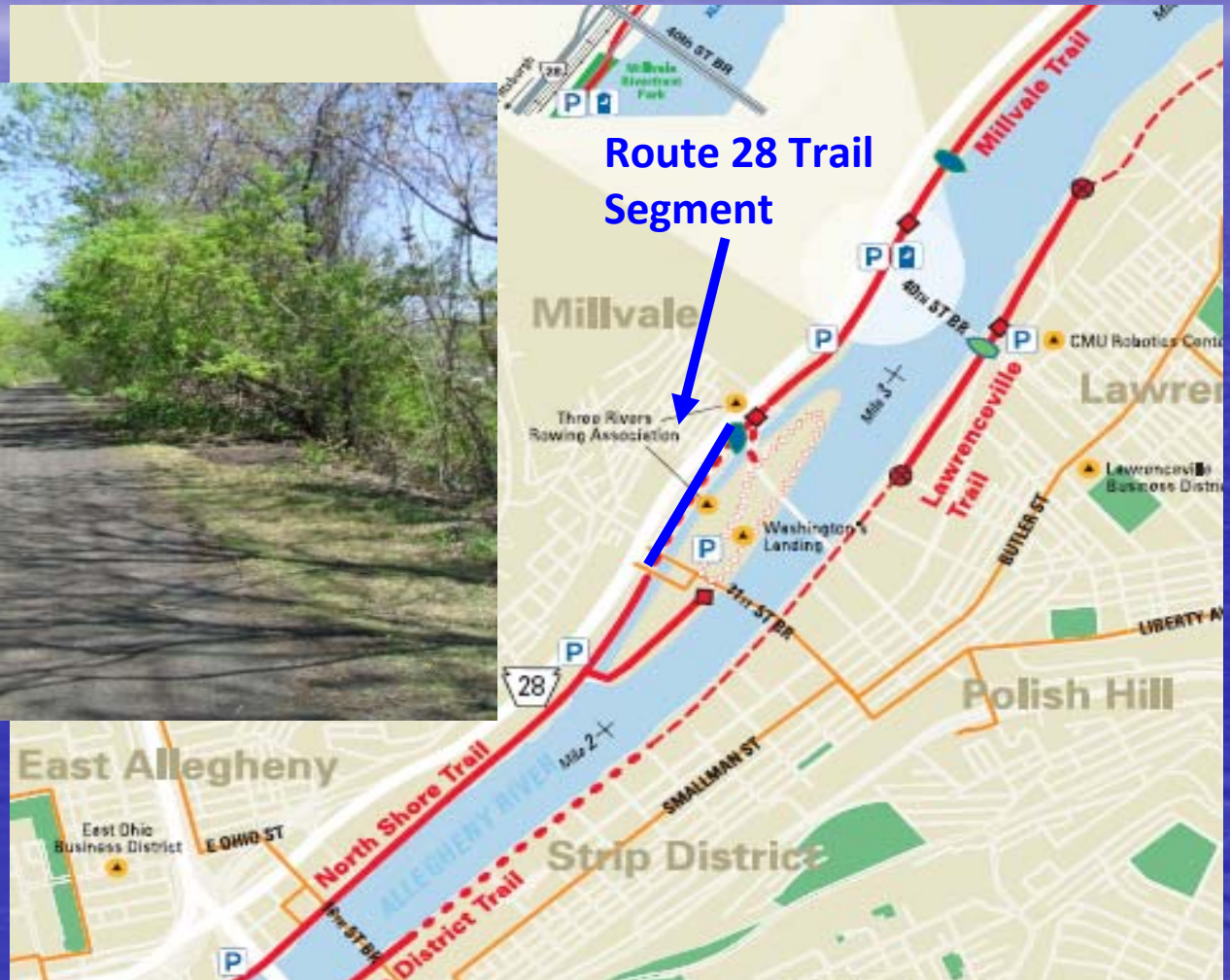

# Justification

- Integral part of the Three Rivers Heritage Trail System.
- Portion of the Pittsburgh to Harrisburg Mainline Canal and Greenway.
- Portion of the Erie to Pittsburgh Trail
- Creates alternative transportation corridor between municipalities.

# Supporting the Initiative

- Allegheny County
- Bike Pittsburgh
- Borough of Millvale
- City of Pittsburgh
- Board and members of Friends of the Riverfront
- PA Department of Community and Economic Development
- PA Department of Conservation and Natural Resources
- PA Environmental Council
- Southwestern PA Commission (regional MPO)
- Washington's Landing Residents

# Funders

- Federal Earmarks
- Heinz Endowments
- Laurel Foundation
- Membership Earmarks
- PA Department of Community and Economic Development
- PA Department of Conservation and Natural Resources
- PA Department of Transportation

# Trail Structure

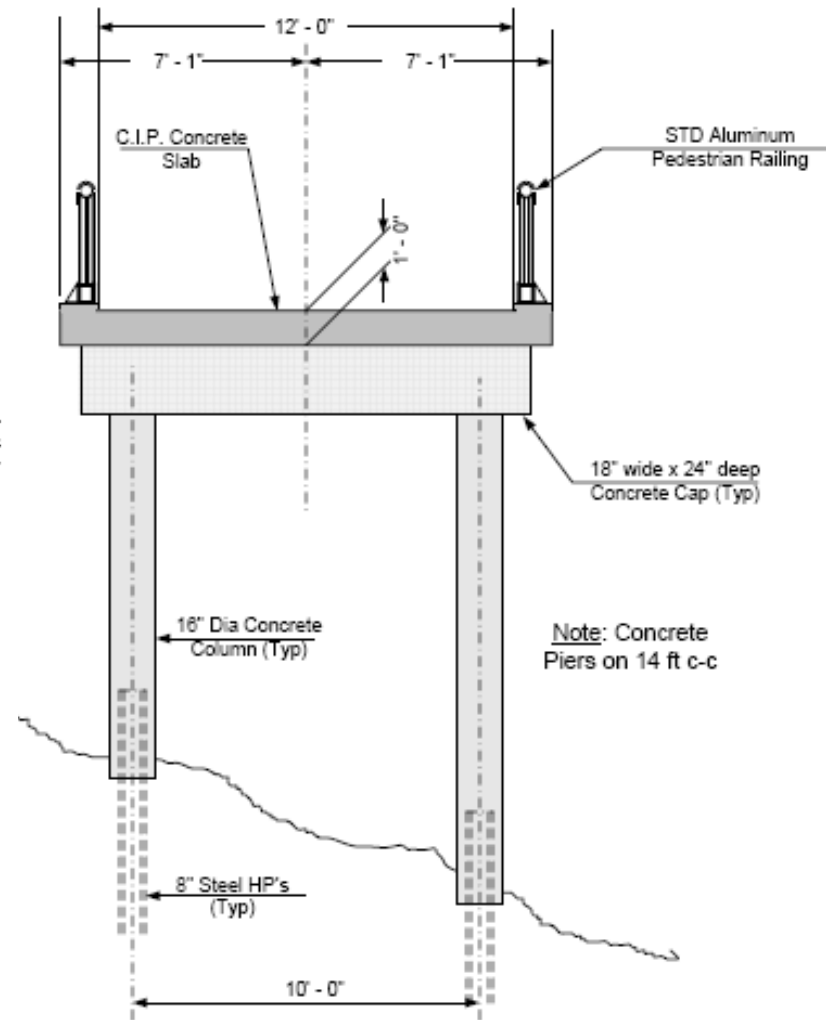
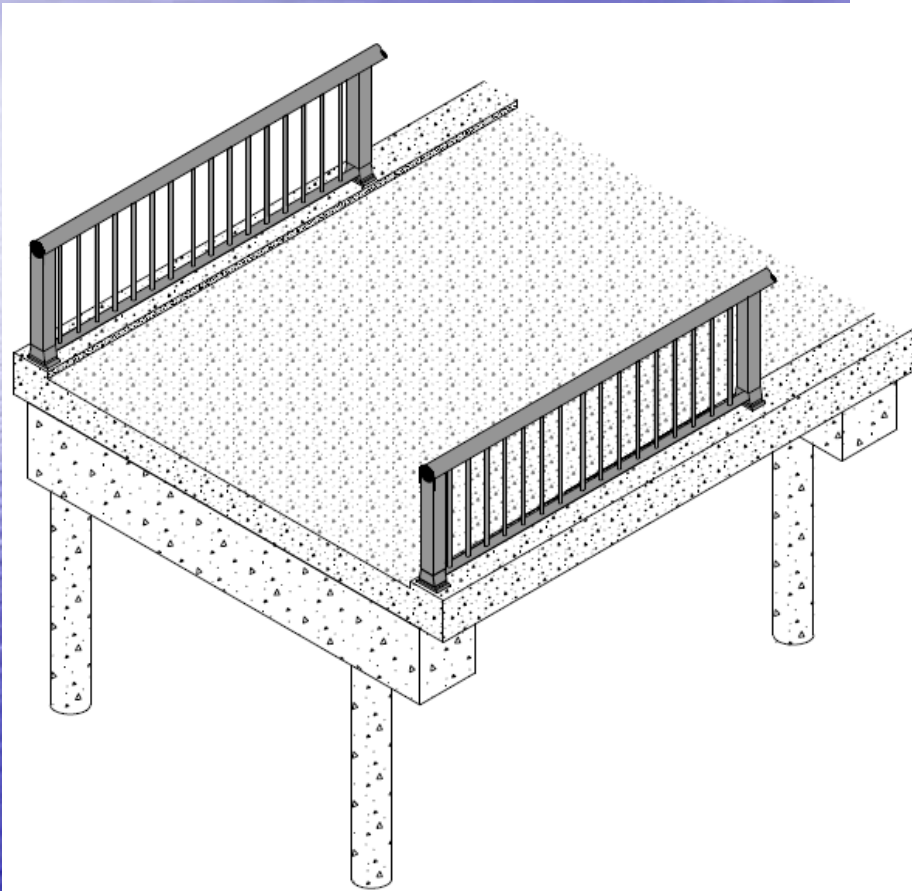

# Role of Friends of the Riverfront

- Assume role of Project Sponsor
- Keep interested stakeholders involved
- Raise funding to complete project
- Keep the project moving
- Thank you and wrap-up

# Role of PA Dept. of Transportation

- Engineering and design
- Environmental clearances
- Bidding of project
- Oversight of construction
- Inspection
- Transfer of project to owner

# Role of City of Pittsburgh

- Assume Role of Fiscal Agent
- Aid in securing funding
- Review and approve design
- Assume ownership of structure as part of the City of Pittsburgh infrastructure

# Upon Completion

- Property and structure will be turned over to the City of Pittsburgh as part of the Three Rivers Heritage Trail.
- Project will serve as a good example of cross organizational planning and cooperation.
- Friends of the Riverfront and our partners will continue to push for trail and greenway development along 90 riverfront municipalities within Allegheny County.

# How can I get involved?

- Stay informed and involved through Social Networks.
- Write a letter of support for Friends of the Riverfront.
- Visit us online at [www.friendsoftheriverfront.org](http://www.friendsoftheriverfront.org) , and become a member!